

Notes, Unless Otherwise Specified:

1. Resistance Values are in Ohms.
2. Capacitance Values are in Microfarads.
3. Inductance Values are in Microhenries.
4. Highest Reference Designator used:
 - A. IC's U58
 - B. Resistors R374
 - C. Capacitors C333
 - D. Inductors L44
 - E. Transistors Q3
 - F. LED D13
 - G. Crystals Y4
 - H. Connectors/Headers J36
 - I. Switches SW2
 - J. Test Points TP4
5. The following is the list of uninstalled parts:
6. All 0.1uF and 0.01uF caps are decoupling caps unless otherwise noted. They are shown on the page with ICs they should be placed near.
7. Board Properties:
 - A. Route to within 10% MANHATTAN Distance
 - B. 50 +/-5 Ohm Matched Impedance
 - C. Outer Layers 0.5 OZ Cu /W 0.5 OZ Au Plating
 - D. Inner Layer 1.0 OZ Cu
 - E. FR4 Board Material
 - F. Minimum Trace Width/Spacing 8 Mils
 - G. Minimum Via Size 12/24 Mils
 - H. Approximate Board Size 9 x 9 cm^2
 - I. Layer Stackup:
 1. Top - Signal Routing
 2. Inner 1 - Signal Routing
 3. Power Plane - Split Plane: +1.8V For DSP Core, +3.3V For DSP I/O
 4. Ground Plane - Split Plane: GND For Digital, AGND For Analog
 5. Inner 2 - Signal Routing
 6. Bottom - Signal Routing

REV	Description	Date	Approved
A	SEED_XDTK-Mboard2.1	2007-10-18	Jessica
B	SEED_XDTK-Mboard3.0	2008-12-25	Jessica

Schematic Index:

1. SEED-XDTK_MB Notes and Contents
2. CPLD & BUZZER & DOT_MATRIX
3. AD & DA
4. VIDEO & USB
5. POWER & LED & NixieTube
6. LCD & Keyboard & RTC & CAN
7. EXTERNAL FEM
8. EXTERANAL_V2Pro
9. SUB_40*2

Revision Status of Sheets

REV	1	2	3	4	5	6	7
SH							
REV							
SH							
REV	B	B					
SH	8	9					
REV	B	B	B	B	B	B	B
SH	1	2	3	4	5	6	7

DWN: Jessica	Date: 2007-12-15
CHK:	Date:
ENGR: Jessica	Date: 2007-12-15
MGR: Jessica	Date: 2007-12-15
QA:	Date:
MFG:	Date:
RLSE:	Date:

Application

 SEED Electronic Technology Ltd.	
Address: No.106 Zhichunlu, Haidian District, Beijing 100086	
Telephone: (010)51518855 FAX: (010)51518866	
Title: SEED_XDTK_MBroadV4.0	
Size: B	Document No.: 5.537.080DL Rev: B
Date: 2007-12-24	Sheet: 1 OF 9

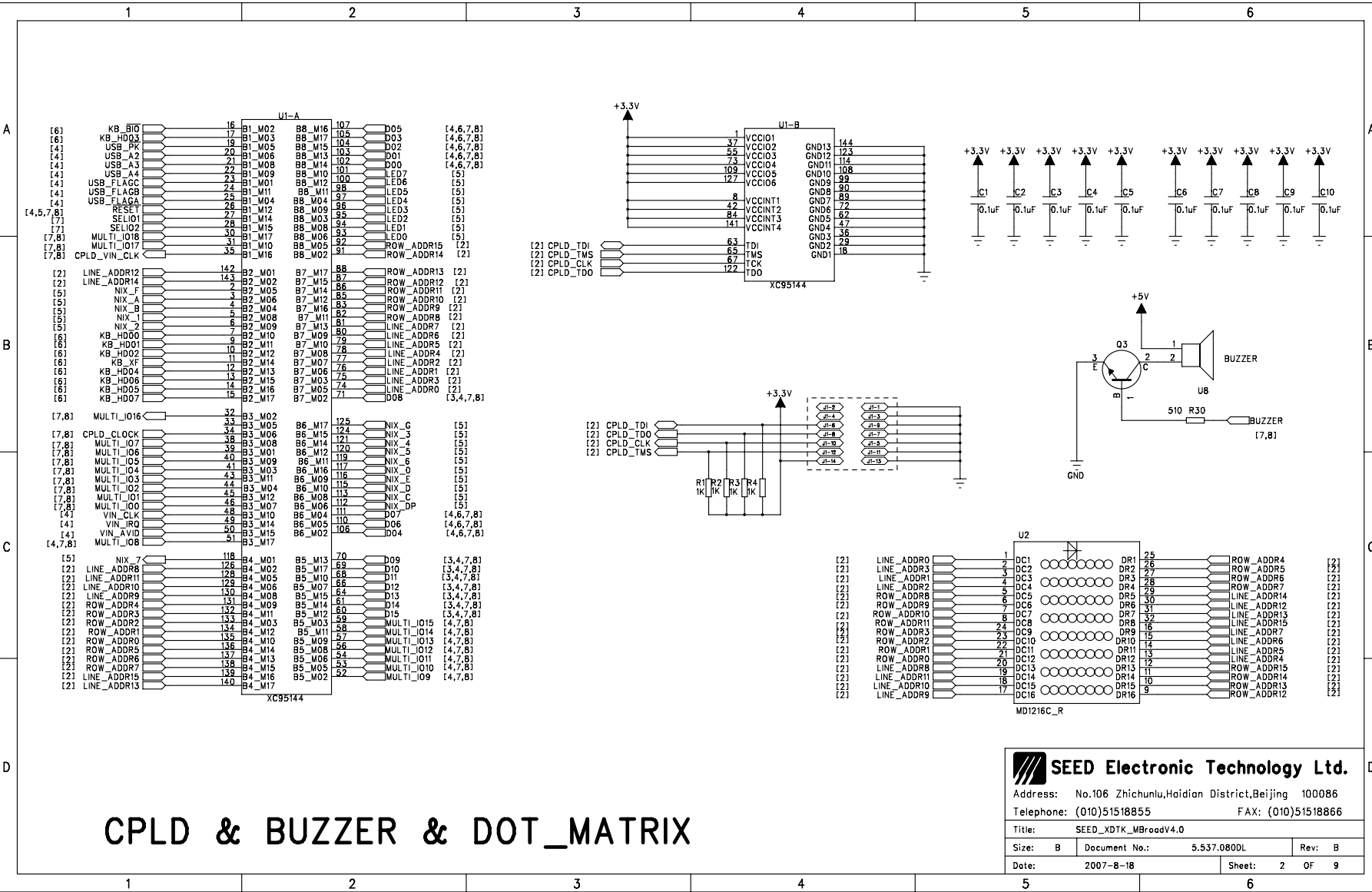

CPLD & BUZZER & DOT_MATRIX

SEED Electronic Technology Ltd.
 Address: No.106 Zhichunlu, Haidian District, Beijing 100086
 Telephone: (010)51518855 FAX: (010)51518866

Title: SEED_XDTK_MBroadV4.0
 Size: B Document No.: 5.537.080DL Rev: B
 Date: 2007-8-18 Sheet: 2 OF 9

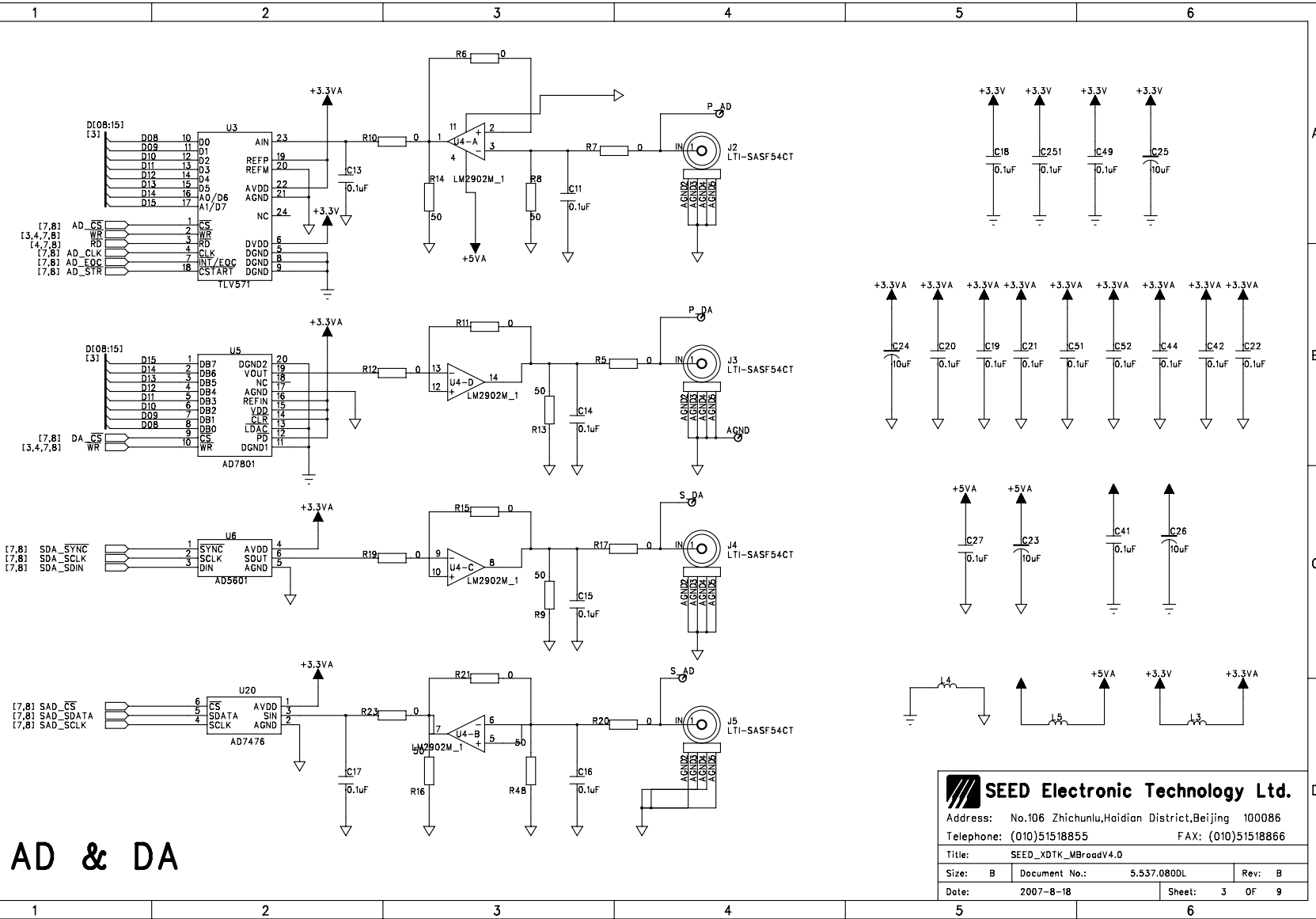

AD & DA

SEED Electronic Technology Ltd.
 Address: No.106 Zhichunlu, Haidian District, Beijing 100086
 Telephone: (010)51518855 FAX: (010)51518866
 Title: SEED_XDTK_MBroadV4.0
 Size: B Document No.: 5.537.080DL Rev: B
 Date: 2007-8-18 Sheet: 3 OF 9

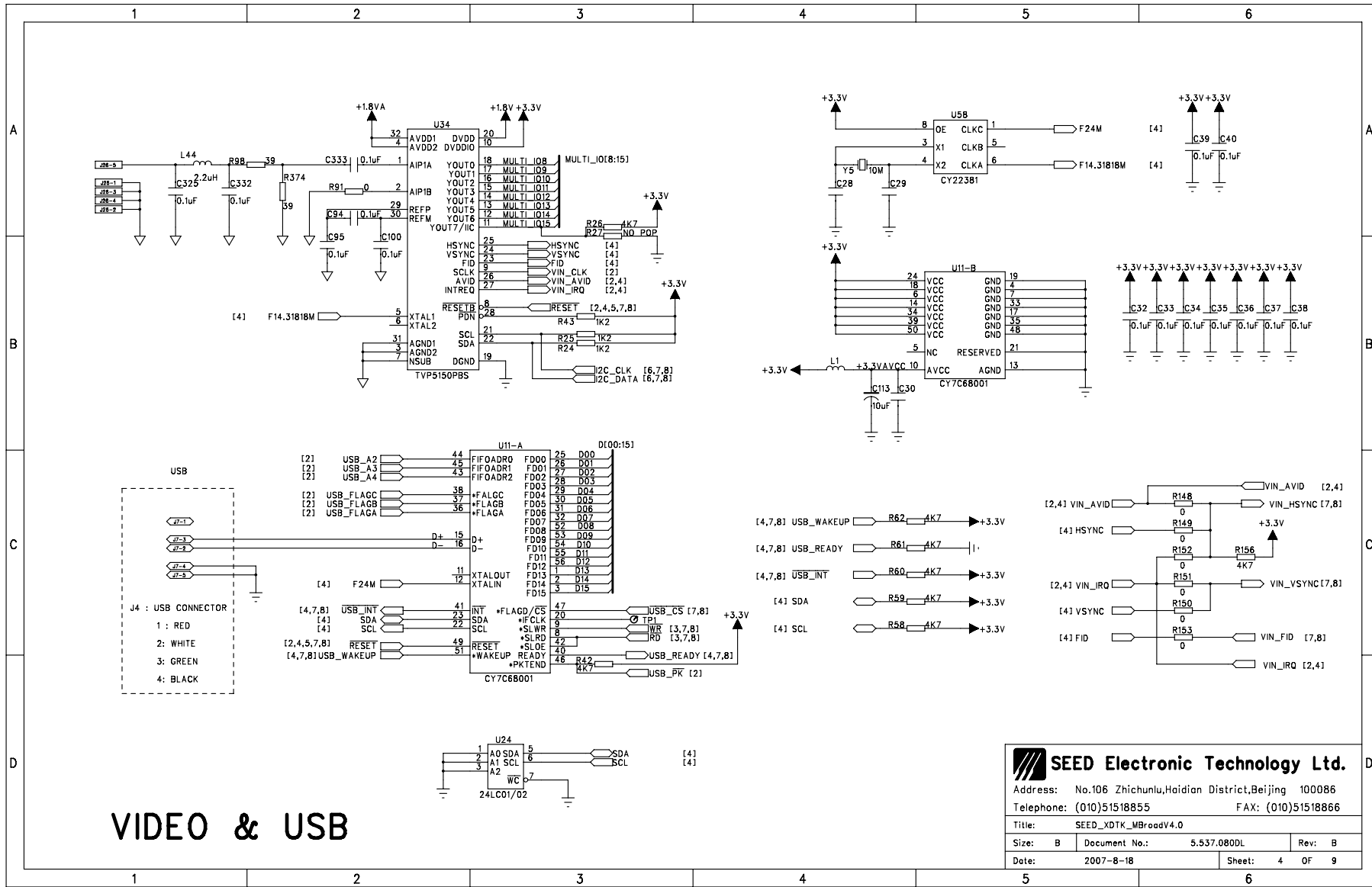

VIDEO & USB

SEED Electronic Technology Ltd.
 Address: No.106 Zhichunlu, Haidian District, Beijing 100086
 Telephone: (010)51518855 FAX: (010)51518866

Title: SEED_XDTK_MBroadV4.0	
Size: B	Document No.: 5.537.080DL
Date: 2007-8-18	Rev: B
Sheet: 4	OF 9

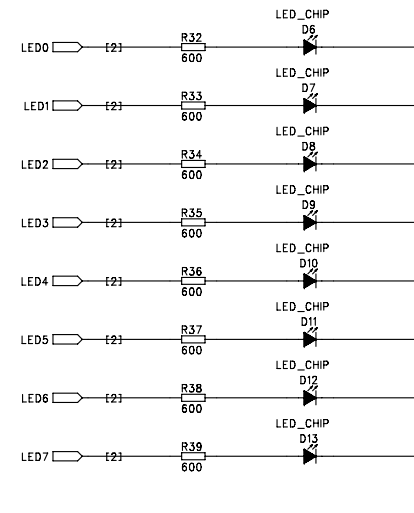
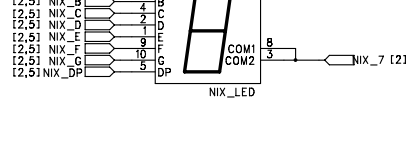
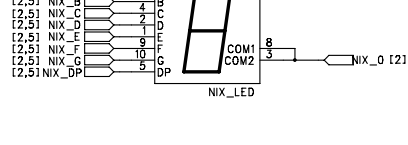
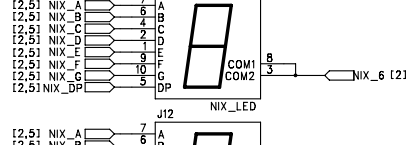
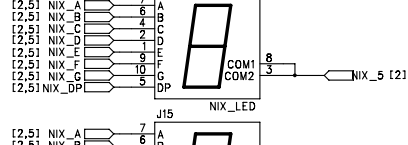
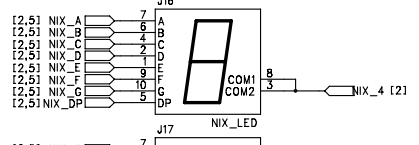
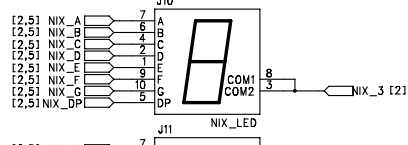
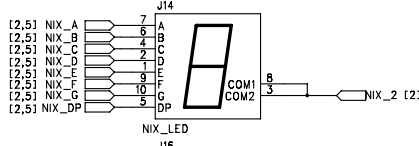
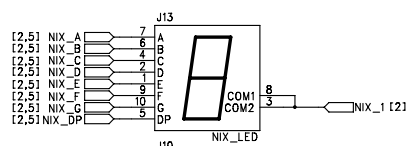
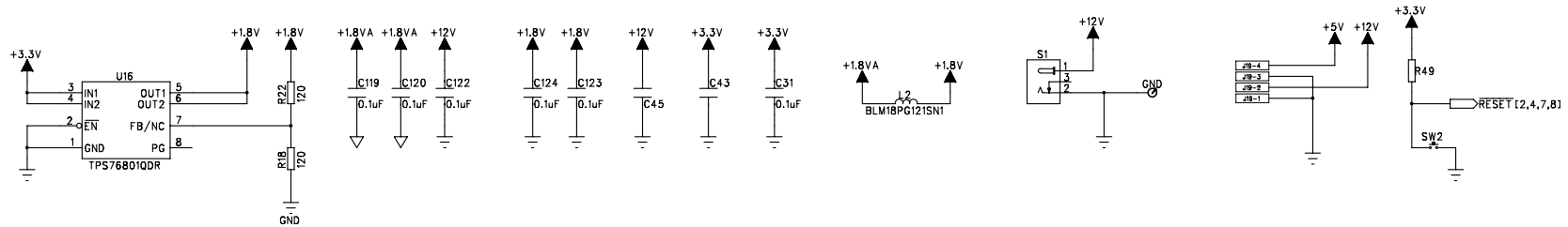

POWER & LED & NixieTube

Address: No.106 Zhichunlu, Haidian District, Beijing 100086	
Telephone: (010)51518855 FAX: (010)51518866	
Title: SEED_XDTK_MBroadV4.0	
Size: B	Document No.: 5.537.080DL Rev: B
Date: 2007-8-18	Sheet: 5 OF 9

1 2 3 4 5 6

A
B
C
D

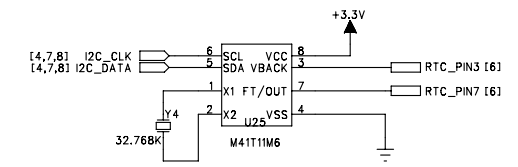
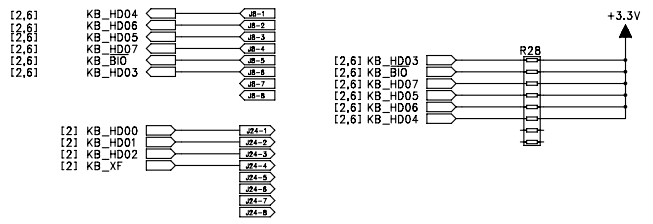
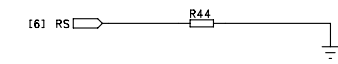
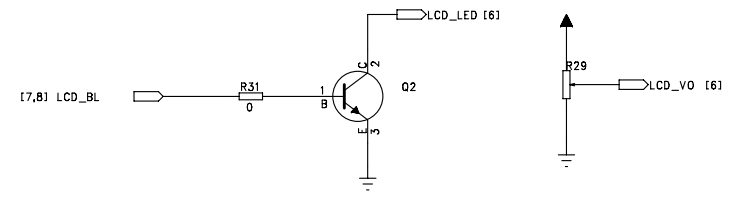
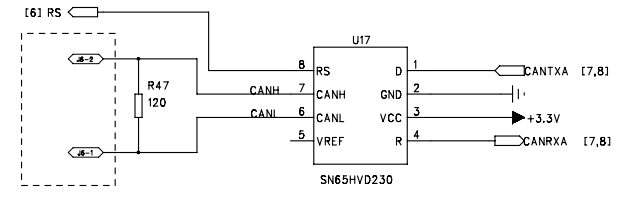
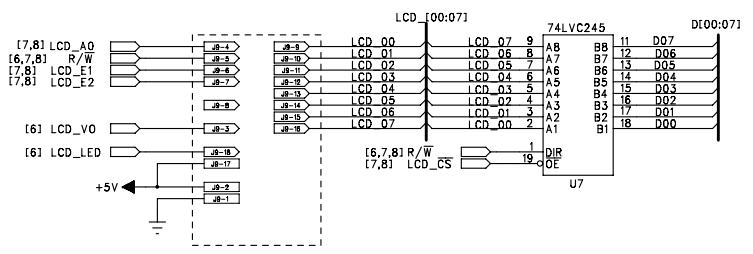

	R63	R65	R66	R62
M41T11M6	x	o	x	o
X1286A81	o	x	o	x

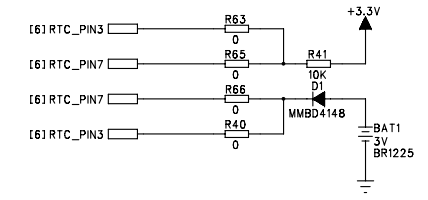

LCD & Keyboard & RTC & CAN

SEED Electronic Technology Ltd.
 Address: No.106 Zhichunlu, Haidian District, Beijing 100086
 Telephone: (010)51518855 FAX: (010)51518866
 Title: SEED_XDTK_MBroadV4.0
 Size: B Document No.: 5.537.080DL Rev: B
 Date: 2007-8-18 Sheet: 6 OF 9

1 2 3 4 5 6

EXTERNAL FEM

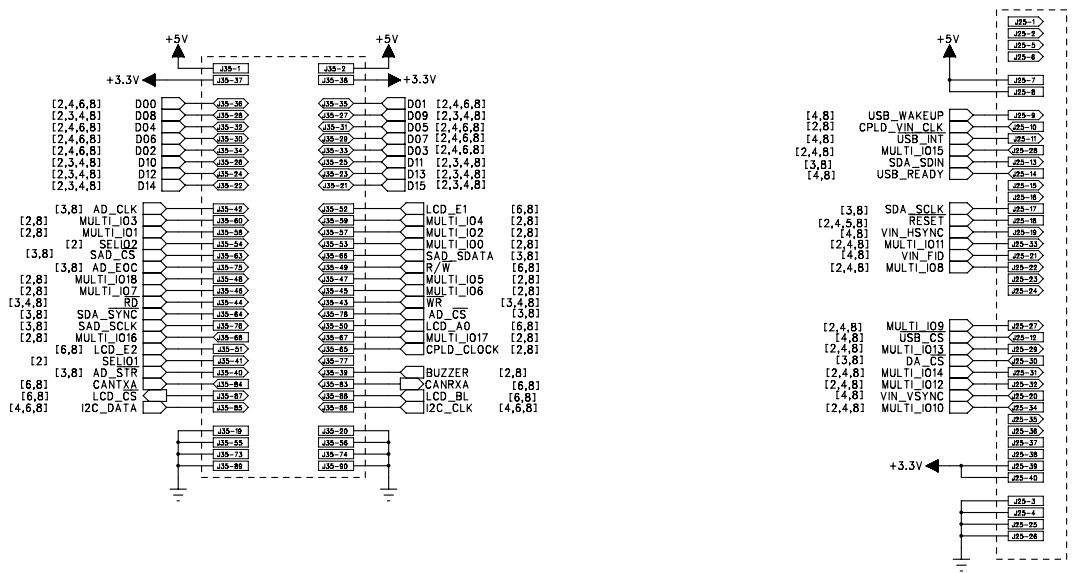

SEED Electronic Technology Ltd.
 Address: No.106 Zhichunlu, Haidian District, Beijing 100086
 Telephone: (010)51518855 FAX: (010)51518866

Title:	SEED_XDTK_MBroadV4.0		
Size:	B	Document No.:	5.537.080DL
Date:	2007-8-18	Sheet:	7 OF 9

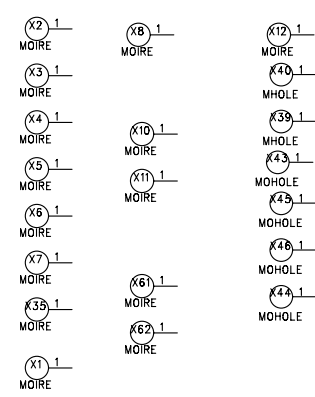
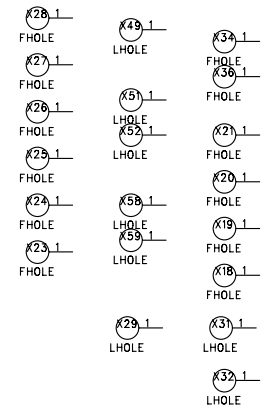
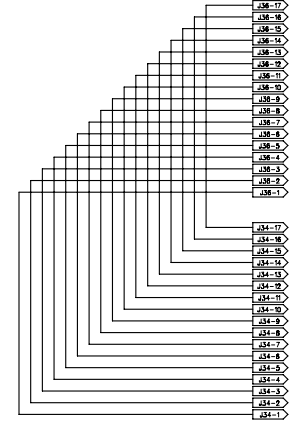
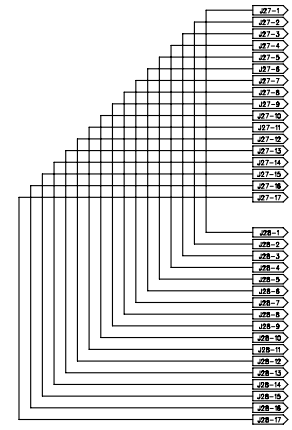
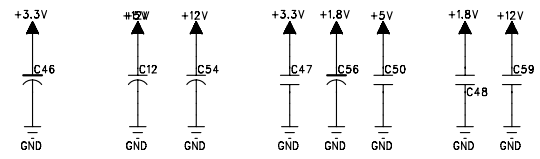
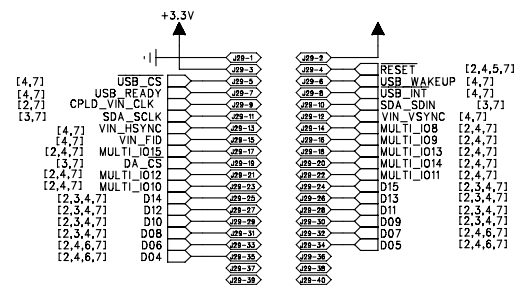
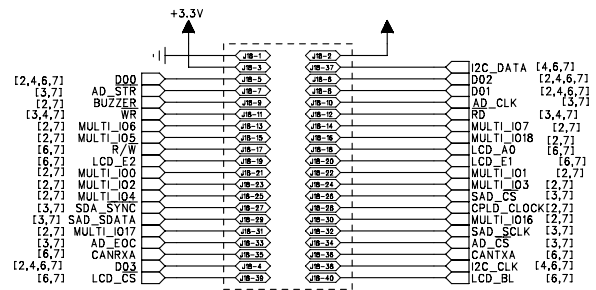

EXTERANAL_V2Pro

SEED Electronic Technology Ltd.
 Address: No.106 Zhichunlu, Haidian District, Beijing 100086
 Telephone: (010)51518855 FAX: (010)51518866
 Title: SEED_XDTK_MBroadV4.0
 Size: B Document No.: 5.537.080DL Rev: B
 Date: 2003-8-19 Sheet: 8 OF 9

SUB_40*2

SEED Electronic Technology Ltd.
 Address: No.106 Zhichunlu, Haidian District, Beijing 100086
 Telephone: (010)51518855 FAX: (010)51518866
 Title: SEED_XDTK_MBroadV4.0
 Size: B Document No.: 5.537.080DL Rev: B
 Date: 2003-8-19 Sheet: 9 OF 9

